

**CONTROL  
CONCEPTS  
INC.**

**INSTRUCTION MANUAL  
MODELS 1022 & 1025**

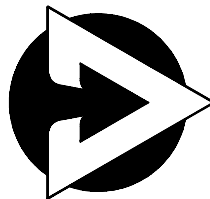

**CONTROL  
CONCEPTS**

7870 PARK DRIVE  
CHANHASSEN, MN 55317  
(952)-474-6200  
1-800-765-2799  
FAX (952) 474-6070

## DESCRIPTION:

The models 1022 and 1025 are single-phase phase-angle SCR power controllers. The controllers are the same except the 1022 accepts command signals of 0-5Vdc, 0-10Vdc or a potentiometer signal. The model 1025 accepts a 4-20mA command signal.

Both controllers control the RMS voltage to the load proportional to the command signal, independent of line voltage changes. The controllers include soft-start and missing cycle detection which on power interruptions of one half cycle or more sets the load voltage to zero and then increases the load voltage to the desired voltage at a predetermined rate. This eliminates inrush currents that can occur due to loads with a low cold resistance or because of saturation when a transformer is used between the controller and the load.

The command signal is electrically isolated from the line and load voltages and all are electrically isolated from the heat sink.

## THEORY OF OPERATION:

The model 1022 and 1025 are phase-angle controllers therefore, the load voltage is controlled by turning the appropriate SCR on for a portion of each electrical half cycle as shown in figure 1.0. The waveform shown as  $E_L$  represents the "ON" time of the SCRs in each half cycle and therefore represents the voltage waveform applied to the load. As the load voltage is increased the SCRs are turned ON earlier in the cycle. As the load voltage is decreased the SCRs are turned on later in cycle. The load voltage can be varied with infinite resolution from 0 to 100 percent of the line voltage. Circuit tolerances may limit the maximum load voltage to about 97% of the supply voltage.

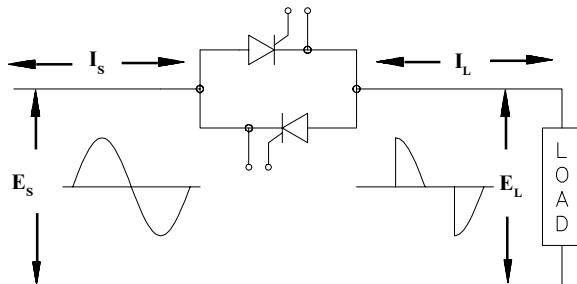

Figure 1.0. Phase angle control at 50% power

## MODEL No. IDENTIFICATION:

**MODEL NUMBER: 102X-VV-AA**  
[-SCXXX] [-MOXX]

**X = 2** for 1022, **5** for 1025

1022 (0-5Vdc, 0-10Vdc or potentiometer control)

1025 (4-20mA input)

**VV** = Rated voltage:

**12**=120;

**24**=240;

**48**= 480;

**57**=570Vac.

**AA** = rated amps: **10, 20, 30, 40,** or **70** amps

Note:

The addition of "-SCXXX" implies that the controller has been modified to have a different input command. For example, a "-SC1/5Vdc" implies the controller has been modified to operate with a 1-5Vdc control signal.

The addition of "-MOXX" implies a special mounting or assembly of the controller.

## INSTALLATION:

The controller must be mounted on a vertical surface such that the heat radiating fins are vertical and located in an environment that will not exceed 135°F and that is protected from dirt and dust.

The wiring must be per local electrical codes. The supply and load terminals will accept up to # 6 wire. The terminals for the circuit transformer and control signals accept wire up to # 14. The terminals for the control signals and circuit transformer are plug-in and may be removed by pulling perpendicular to the circuit card.

### CAUTION:

1. The circuit transformer must be connected to the same supply as the controller and the load. A common installation error has been that of the circuit transformer being powered from a different phase or being connected across the SCR module rather than from the supply.
2. Do not over tighten the wire connections.

**NOTE:** It is recommended that the controller and the load be protected with fast acting class "T" fuses such as described in the specification portion or this instruction manual.

<b>SPECIFICATIONS:</b>								
<b>Control Mode</b>		Single-phase; Phase-angle; RMS value of the voltage applied to the load						
<b>Command Signal</b>		SIGNAL Model 1022: 0-5Vdc 0-10VDC & Pot (1K pot recommended, 20K permissible) Model 1025: 4-20mA;			INPUT IMPEDANCE 100K 200K 200 ohms			
<b>Control Range</b>		6 to 97% of line voltage typical.						
<b>Linearity</b>		RMS load voltage is linear within 2% of span of the command signal.						
<b>Zero and Span Adjustment</b>		User adjustable over range of $\pm 20\%$ of span.						
<b>Isolation</b>		Dielectric strength input/line & load voltage/heatsink 4000V <sub>(RMS)</sub> . Insulation resistance input/line & load voltage/heatsink $10^{10}$ ohms. Maximum capacitance input to output 8pf.						
<b>Cooling</b>		Convection						
<b>Mounting</b>		Must be mounted on vertical surface with fins vertical. Units may be mounted adjacent to each other. Heat sink is electrically isolated.						
<b>Line voltage</b>		120, 240, 480 or 575Vac $\pm 10\%$ , $-20\%$ 50/60 Hertz						
<b>Diagnostic Indicator</b>		The intensity of an LED varies as a function of the command signal. Feature provides a quick and safe means to check controller operation.						
<b>Physical</b>		Weight: 10 thru 40 amp 2 lbs , 70 amp 6 lbs Dimensions: Refer to installation drawing						
<b>Environment</b>		Operating: 0 to 55°C (32 to 131°F) Storage: -40 to 80°C (-40 to 176°F) Humidity: 0 to 95% Non-condensing						
<b>dv/dt &amp; Transient Voltage</b>		200 volts/usec minimum A dv/dt snubber and a metal oxide varistor (MOV) are provided to protect against high frequency transients (dv/dt) and voltage spikes.						
<b>Dissipation</b>		1.5 watt per amp of controlled current						
<b>Recommended Fusing</b>		Special semiconductor fuses are not required. It is recommended that the controller and load be protected with fast acting class "T" fuses such as Bussmann type JJS or JJN fuses. Control Concepts maintains an inventory of fuses and fuse holders for your convenience.						
<b>SURGE CURRENT RATINGS</b>				<b>KW</b>				
Continuous RMS rating	RMS 1 Second	Peak 1 cycle (Non-Repetitive)	I <sup>2</sup> t rating	120Vac	240Vac	277Vac	480Vac	575Vac
10	22	140	81	1.20	2.40	2.77	4.80	5.75
20	40	250	260	2.40	4.80	5.54	9.60	11.50
30	80	625	1620	3.60	7.20	8.31	14.40	17.25
40	150	1000	4150	4.80	9.60	11.08	19.20	23.00
70	150	1000	4150	8.40	16.80	19.39	33.60	40.25

# INSTALLATION DRAWINGS:

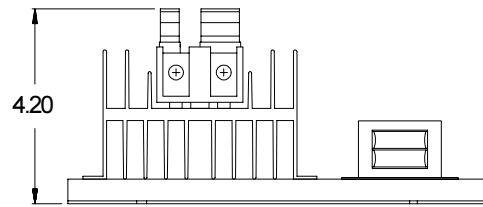
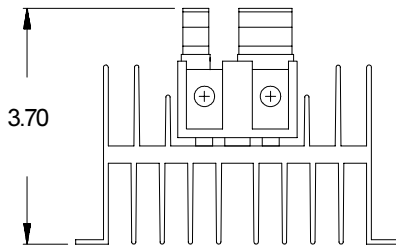
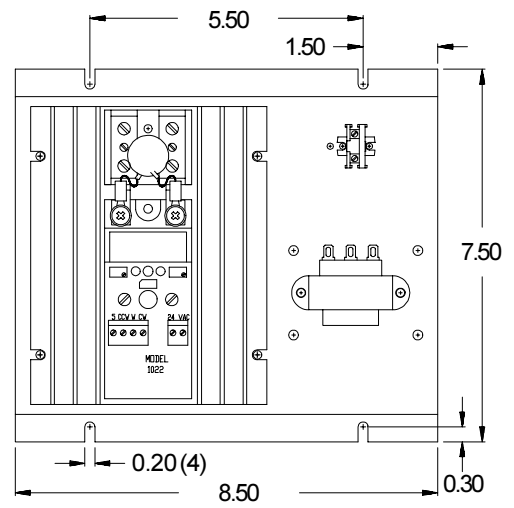
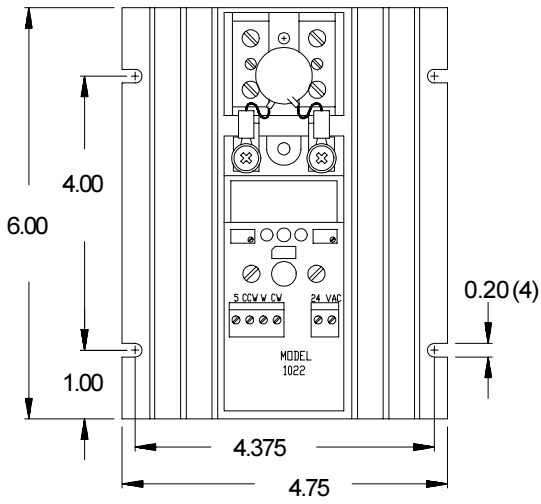

**10, 20, 30 & 40 AMP**

**"-MO1" Mounting Option**

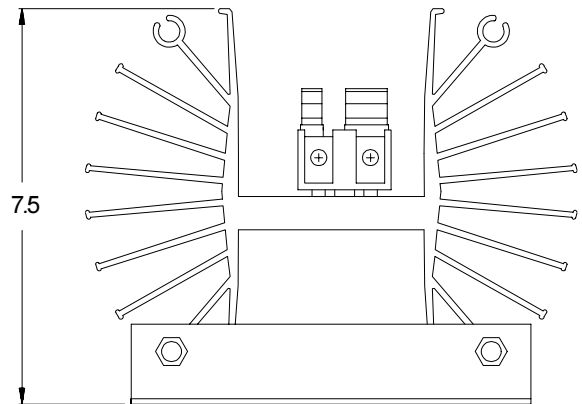
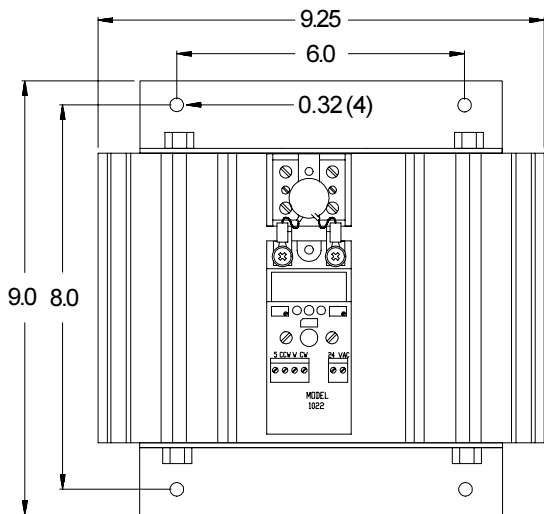

**70 AMP**

### MODEL 1022 CONNECTIONS:

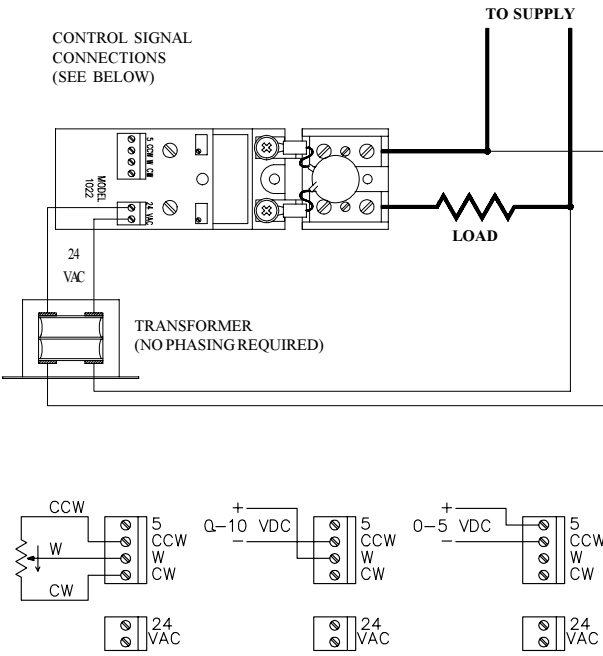

### MODEL 1025 CONNECTIONS:

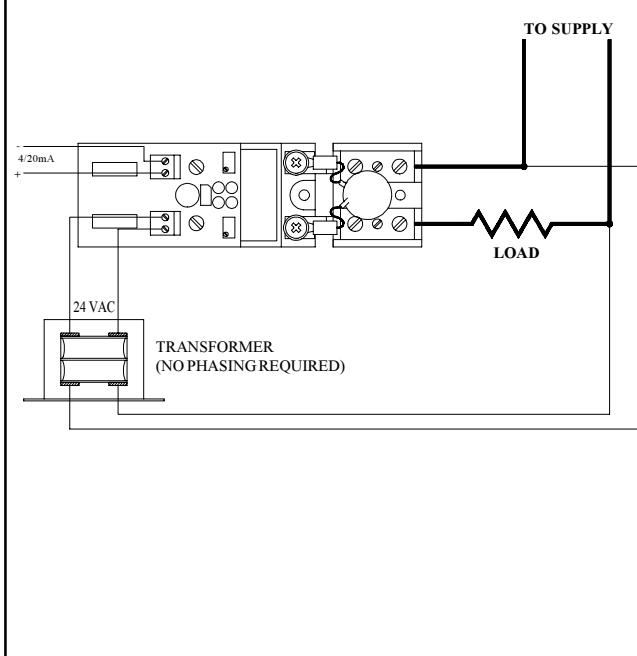

### RECOMMENDED SPARE PARTS AND FUSES

MODEL:	SCR MODULE (ASSEMBLY) CCI PART #	FUSES FOR RESISTIVE AND TRANSFORMER COUPLED LOADS	
		CCI PART #	BUSSMAN #
1022-12-10	1652-12-10	42110-0430-315	JJN-15
1022-12-20	1652-12-20	42110-0430-325	JJN-25
1022-12-30	1652-12-30	42110-0430-335	JJN-35
1022-12-40	1652-12-40	42110-0430-350	JJN-50
1022-12-70	1652-12-70	42110-0430-390	JJN-90
1022-24-10	1652-24-10	42110-0430-315	JJN-15
1022-24-20	1652-24-20	42110-0430-325	JJN-25
1022-24-30	1652-24-30	42110-0430-335	JJN-35
1022-24-40	1652-24-40	42110-0430-350	JJN-50
1022-24-70	1652-24-70	42110-0430-390	JJN-90
1022-48-10	1652-48-10	42110-0460-315	JJS-15
1022-48-20	1652-48-20	42110-0460-325	JJS-25
1022-48-30	1652-48-30	42110-0460-335	JJS-35
1022-48-40	1652-48-40	42110-0460-350	JJS-50
1022-48-70	1652-48-70	42110-0460-390	JJS-90
1022-57-10	1652-57-10	42110-0460-315	JJS-15
1022-57-20	1652-57-20	42110-0460-325	JJS-25
1022-57-30	1652-57-30	42110-0460-335	JJS-35
1022-57-40	1652-57-40	42110-0460-350	JJS-50
1022-57-70	1652-57-70	42110-0460-390	JJS-90

## **TROUBLE SHOOTING:**

**CAUTION:** High voltage exists on the supply and load terminals of this controller and may exist on other equipment located near the controller. Use extreme caution to avoid electrical shock.

The LED located on the controller circuit can be used to aid in determining problems. This LED varies in intensity proportional to the command signal and therefore should be proportional to the load voltage.

THE FOLLOWING ARE SYMPTOMS AND POSSIBLE CAUSES:

### **NO LOAD POWER: LED not ON:**

Determine that the command signal is applied to the controller. Determine that 24 volts is applied to the circuit.

### **NO LOAD POWER: LED intensity can be varied:**

Determine that all fuses are "OK". If the voltage across the SCR module is equal to the line voltage the SCR module has probably failed. NOTE: If a replacement SCR module is ordered specify the voltage and current rating of the controller and the serial number of the failed unit.

### **LOAD POWER IS MAXIMUM AND CANNOT BE REDUCED: LED is ON:**

Determine that the command signal can be adjusted to zero. Also remove the green plug-in connector to remove the command signal. If the LED is not off, the circuit card has failed.

### **LOAD POWER IS MAXIMUM AND CANNOT BE REDUCED: LED is OFF:**

Remove the 24Vac plug in connector. If the load still has power the SCR module has probably failed as a short allowing full power at be applied to the load. To determine if the SCR module has shorted remove power and then the line and load connections and measure the resistance across the line and load terminals on the SCR module. If the resistance is less than 10000 ohms the modual has failed. NOTE: If a replacement SCR module is ordered specify the voltage and current rating of the controller and the serial number of the failed unit.

### **LOAD VOLTAGE SNAPSON:**

Determine that the primary of the circuit transformer is connected to the same supply as the controller and load.

### **MAXIMUM LOAD VOLTAGE CANNOT BE OBTAINED:**

Determine that the primary of the circuit transformer is connected to the same supply as the controller and load. Typically this problem is caused by the primary being connected across the load and line connection at the controller.

## **ZERO AND SPAN ADJUSTMENTS:**

The zero and span adjustments have been factory adjusted to provide zero load voltage when the minimum command signal is applied and to provide rated output voltage to the load when the maximum command signal is applied. Further adjustment of these settings should not be required. If it is desired to readjust the zero and span settings the following procedures should be followed. **NOTE** Voltage and/or current measurements should be taken with meters that provide true RMS readings due to the chopped waveforms provided by the SCR controller. Adjust the zero potentiometer with the minimum command signal applied such that the load voltage is just zero. (Clockwise rotation of both the span and zero potentiometer increase the load voltage) Adjust the span potentiometer with the maximum command signal applied such that load voltage equals the rated voltage of the controller. It may be necessary to repeat these steps due to interaction that can occur. The 1022 and 1025 controllers have line voltage compensation therefore if the supply voltage is above the nominal rating the controller will supply the nominal rated voltage to the load. For example, if a controller rated for 240 volt operation is supplied from a 260 volt supply and the maximum command signal is applied the controller will supply only 240 volts to the load thereby eliminating the effects of line voltage changes.

## **REFERENCE DRAWINGS:**

Model 1022: Schematic B1000466  
Model 1025: Schematic B1000324

Transformer Inst. Dwg. AS1401

## **MANUFACTURED BY:**

